

# TECHNICAL BULLETIN

LTB00051

20 APR 2007



© Jaguar Land Rover Limited  
All rights reserved.

## **SECTION: 303-06**

The Starter Motor Solenoid Is Now Available as a Serviceable Part

### **AFFECTED VEHICLE RANGE:**

<b>Defender (LD) - Td5 Diesel</b>	<b>VIN:</b>	<b>XA159810-6A732614</b>
<b>Discovery 3 / LR3 - AJV8 Petrol (Supercharged and Naturally Aspirated) - Cologne V6 Petrol</b>	<b>VIN:</b>	<b>5A000303 Onwards</b>
<b>Discovery Series II (LT) - Td5 Diesel</b>	<b>VIN:</b>	<b>Start VINs VA200000 - XA900000-End VINs 4A870624 - XA907214</b>
<b>Freelander (LN) - Td4 Diesel - KV6 Petrol</b>	<b>VIN:</b>	<b>1A576764-6A833722</b>
<b>Freelander 2 - 2.2L Diesel</b>	<b>VIN:</b>	<b>7H000200 Onwards</b>
<b>Range Rover (LM) - AJV8 Petrol (Supercharged and Naturally Aspirated)</b>	<b>VIN:</b>	<b>6A198058 Onwards</b>
<b>Range Rover Sport (LS) - AJV8 Petrol (Supercharged and Naturally Aspirated)</b>	<b>VIN:</b>	<b>6A900290 Onwards</b>

### **MARKETS:**

All

### **CONDITION SUMMARY:**

**Situation:** This is to make the Authorized Repairers aware that the starter motor solenoid is now available as a serviceable part on the models/derivatives listed above. Therefore the complete starter motor assembly no longer requires replacing for solenoid concerns (please follow the diagnostic aid in the Service Instruction for accurate diagnosis).

### **PARTS:**

NAF500010	Starter Solenoid - Defender Td5/Discovery II TD5	Quantity: 1
LR005977	Starter Solenoid - Discovery III - V6 Cologne Petrol	Quantity: 1
LR005973	Starter Solenoid - Discovery III/RR Sport - AJV8 Petrol	Quantity: 1

LR005978	Starter Solenoid - Freelander I - KV6	Quantity: 1
LR005975	Starter Solenoid - Freelander I - Td4	Quantity: 1
LR005976	Starter Solenoid - Freelander II - 2.2L Diesel	Quantity: 1
LR005974	Starter Solenoid - Range Rover - AJV8 Petrol	Quantity: 1

## **WARRANTY:**



**NOTE: Repair procedures are under constant review, and therefore times are subject to change; those quoted here must be taken as guidance only. Always refer to TOPIx to obtain the latest repair time.**



**NOTE: DDW requires the use of causal part numbers. Labor only claims must show the causal part number with a quantity of zero.**

DESCRIPTION	SRO	TIME
Starter Solenoid - Renew - Defender Td5	<b>86.60.08</b>	1.10 hours
Starter Solenoid - Renew - Discovery II TD5	<b>86.60.08</b>	0.50 hours
Starter Solenoid - Renew - Discovery III - Cologne V6 Petrol	<b>86.60.08</b>	1.60 hours
Starter Solenoid - Renew - Discovery III - AJV8	<b>86.60.08</b>	1.90 hours
Starter Solenoid - Renew - Freelander I Td4	<b>86.60.08</b>	1 hour
Starter Solenoid - Renew - Freelander I KV6	<b>86.60.08</b>	0.90 hours
Starter Solenoid - Renew - Freelander II TD4	<b>86.60.08</b>	0.60 hours
Starter Solenoid - Renew - Range Rover AJV8 (Naturally Aspirated and Supercharged)	<b>86.60.08</b>	1.10 hours
Starter Solenoid - Renew -Range Rover Sport AJV8 (Naturally Aspirated and Supercharged)	<b>86.60.08</b>	1.30 hours



**NOTE: Normal Warranty procedures apply.**

## **SERVICE INSTRUCTION:**

### **Inspection and verification**

1. Verify the customer concern.
2. Visually inspect for obvious mechanical or electrical faults.

<b>Mechanical</b>	<b>Inspection and verification</b>
Gear selector lever cable adjustment (vehicles with automatic transmission)	Battery state of charge
Engine (turns freely)	Incorrect battery fitted
Starter motor pinion gear damaged, seized	Fuses
Flywheel/drive plate ring gear damaged	Starter relay
.	Wiring Harness(es) and connectors
.	Damaged, loose or corroded battery or starter cables and connections
.	Damaged, loose or corroded engine earth cable and connections
.	Ignition switch
.	Generator
.	Engine control module (ECM)
.	Transmission control module (TCM)

3. If an obvious cause for an observed or reported concern is found, correct the cause (if possible) before proceeding to the next step.

Use the approved diagnostic system or a scan tool to retrieve any diagnostic trouble codes (DTCs) before moving onto the symptom chart or DTC index.

Make sure all DTCs are cleared following rectification.

## Diagnosis and Testing

### Symptom Chart

Symptom	Possible Causes	Action
The engine does not crank (starter motor does NOT turn)	Gear selector not in 'P' or 'N' position (vehicles with automatic transmission). Battery state of charge. Starter relay circuit fault. Invalid key code. Harness/Connectors. Ignition switch fault. Generator fault. Engine seized. Starter motor solenoid fault. Starter motor fault.	Make sure the gear selector is in the 'P' or 'N' position and correctly adjust. Check battery condition and state of charge. Check for DTCs indicating an immobilizer fault. Check the starter motor relay, ignition switch and generator circuits. Refer to the electrical guides. Check that the engine turns freely. During cranking confirm that the voltage at the starter motor solenoid terminals (battery positive terminal and starter relay terminal) is also present at the motor positive terminal. If no voltage is present at the motor positive terminal during cranking then the starter motor solenoid should be replaced. Disconnect battery, remove starter motor and install the starter motor service kit.
The engine does not crank (starter motor DOES turn)	Starter motor installation. Starter motor fault. Flywheel/Drive plate ring gear.	Check the starter motor installation (fasteners tight, starter motor square to engine, etc). Check the starter motor and flywheel/drive plate ring gear teeth for damage, foreign objects, etc.

## Starter Solenoid - Removal and Installation

### Removal

1 Remove the starter motor (see Global Technical Reference GTR Workshop Manual, section: 303-06 or 86-1).

2  **NOTE: Range Rover V8 shown; all other models similar.**

Release the starter motor terminal cover.

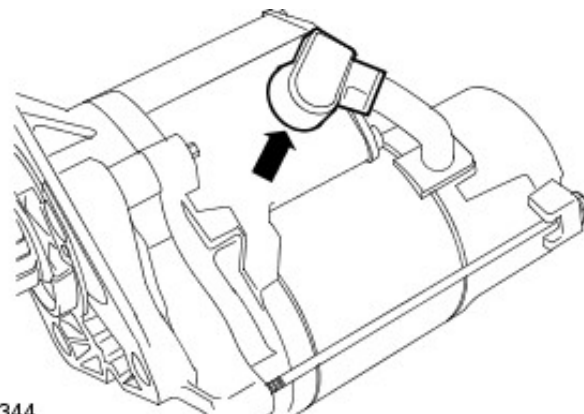

3  **NOTE: Range Rover V8 shown; all other models similar.**

Release the starter motor terminal.

1. Remove the nut.

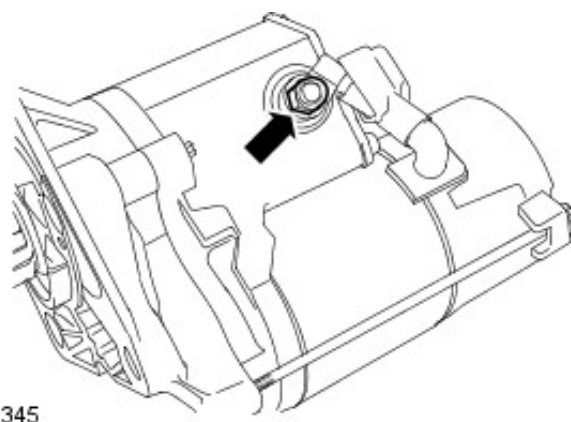

4  **NOTE: Range Rover V8 shown; all other models similar.**

Remove the starter motor bolts.

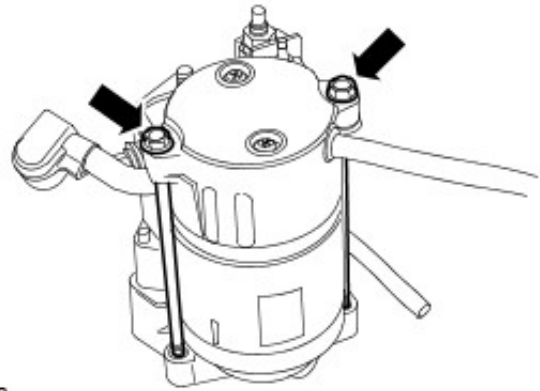

E92220

- 5  **CAUTION: Make sure the starter motor armature remains located inside the motor housing.**

 **NOTE: Range Rover V8 shown; all other models similar.**

Remove the starter motor from the gear housing.

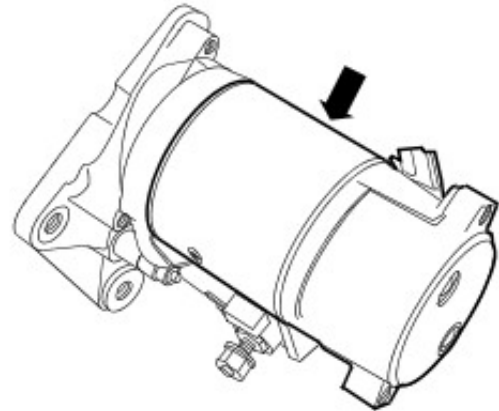

E 92346

- 6  **NOTE: Range Rover V8 shown; all other models similar.**

Remove the starter solenoid screws.

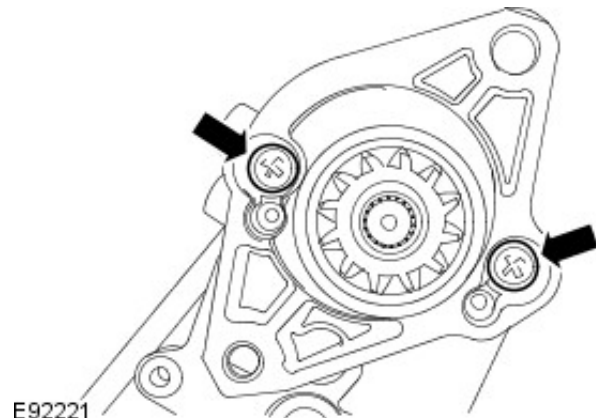

E92221

- 7  **CAUTION: Make sure the gears and bearings remain located in the gear housing.**

 **NOTE: Range Rover V8 shown; all other models similar.**

Remove the starter solenoid.

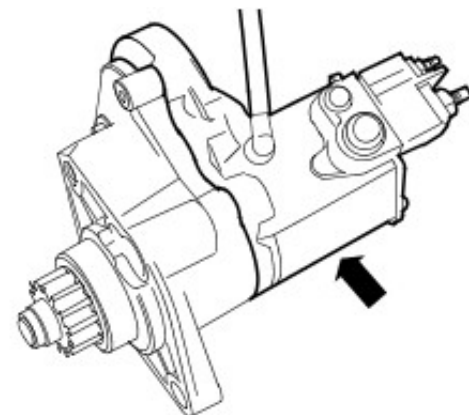

E92222

## Installation

- 8  **CAUTION: Make sure the gears and bearings remain located in the gear housing.**

Install the starter solenoid to the gear housing.

9 Install the starter solenoid screws and tighten to 10Nm (7lb. ft).

10 Install the starter motor to the gear housing.

11 Install the starter motor bolts and tighten to 10Nm (7lb. ft).

**12**Secure the starter motor terminal and tighten to 5Nm (4 lb. ft).

**13**Secure the starter motor terminal cover.

**14**Install the starter motor (see Global Technical Reference GTR Workshop Manual, section: 303-06 or 86-1).